

NOTE: UNLESS OTHERWISE SPECIFIED:

1. PARTIAL REFERENCE DESIGNATIONS ARE SHOWN FOR DETAIL PARTS. PREFIX THESE WITH UNIT NO. AND/OR ASSEMBLY DESIGNATIONS SHOWN ON DRAWING TO OBTAIN COMPLETE DESIGNATIONS.
2. ALL RESISTOR VALUES ARE IN OHMS, 1/4W, ±5%.
3. ALL CAPACITOR VALUES ARE IN MICROFARADS (UF).
4. ALL INDUCTANCE VALUES ARE IN MICROHENRIES (UH).
5. VENDOR PART NO. CALLOUTS ARE FOR REFERENCE ONLY. COMPONENTS ARE SUPPLIED PER PART NO. IN PARTS LIST.
6. DC RESISTANCES OF INDUCTIVE ELEMENTS (CHOKES, COILS, MOTOR WINDINGS, ETC.) ARE LESS THAN 1 OHM.
7. PANEL DECALS ARE INDICATED BY BOLD TYPE IN A BOLD BOX, E.G., **ON/OFF**
8. ALL RELAYS ARE SHOWN IN THE DE-ENERGIZED STATE.

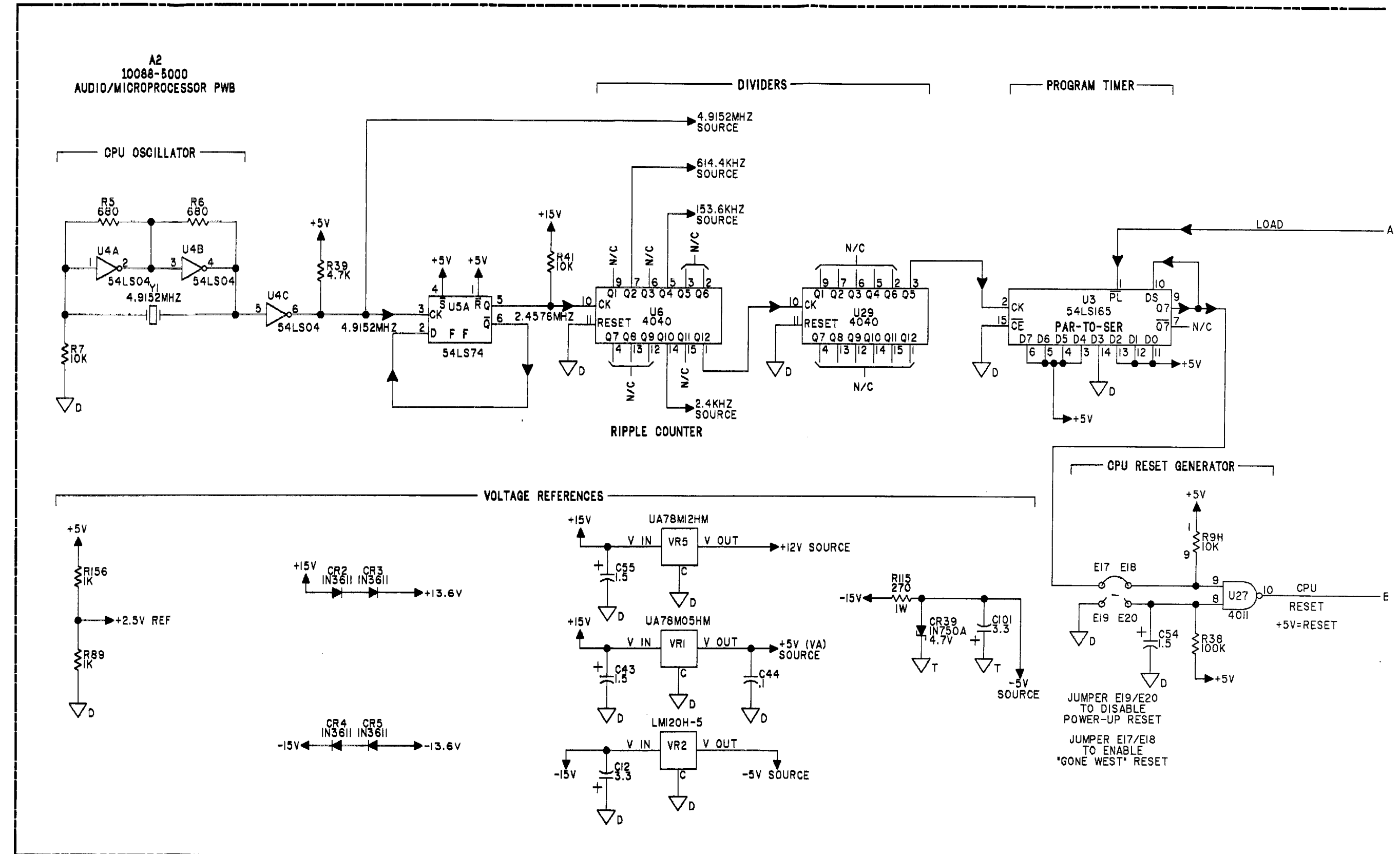

FO-6. Audio/Microprocessor PWB Assy, A2 (Sheet 1 of 19)

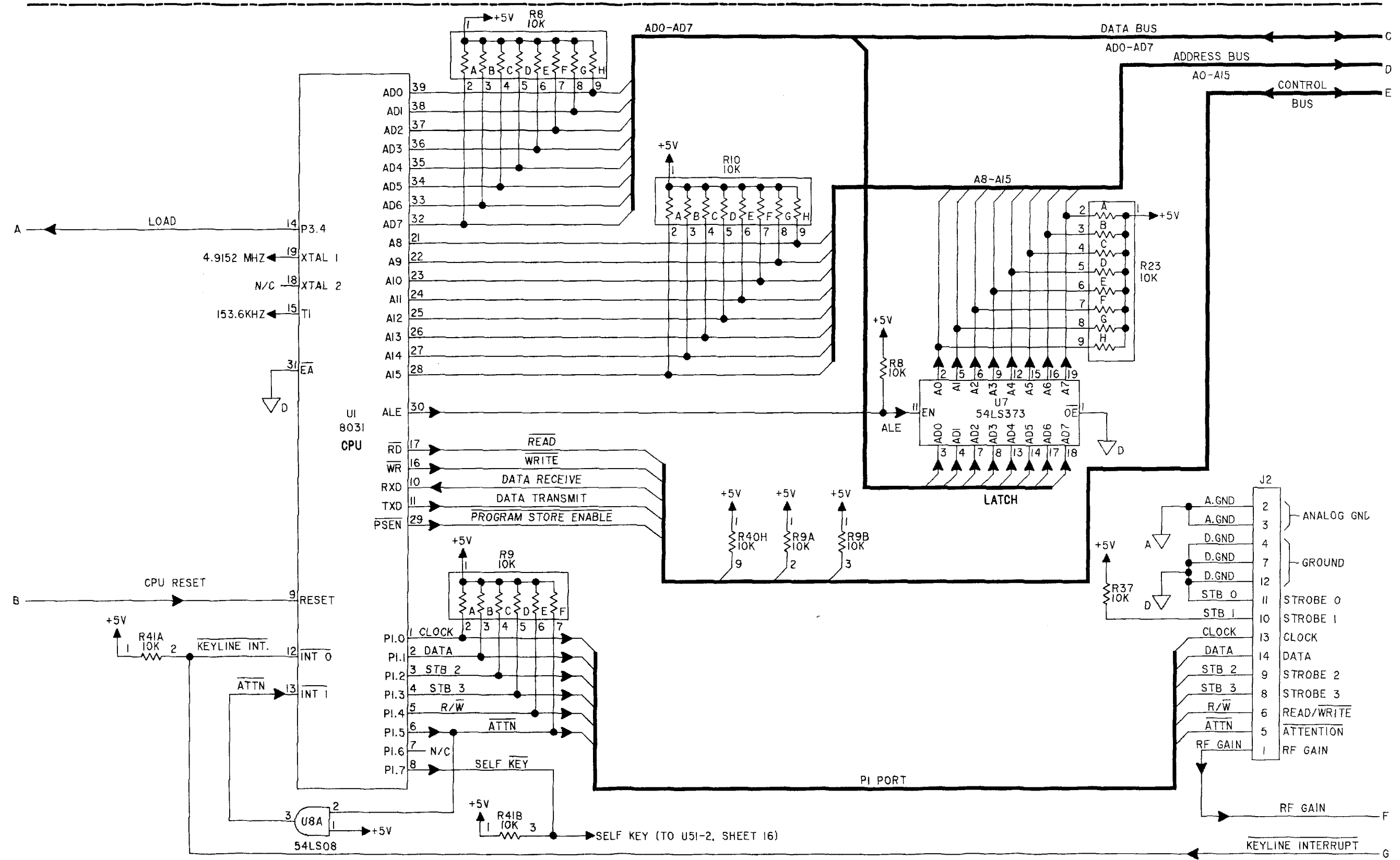

FO-6. Audio/Microprocessor PWB Assy, A2 (Sheet 2 of 19)

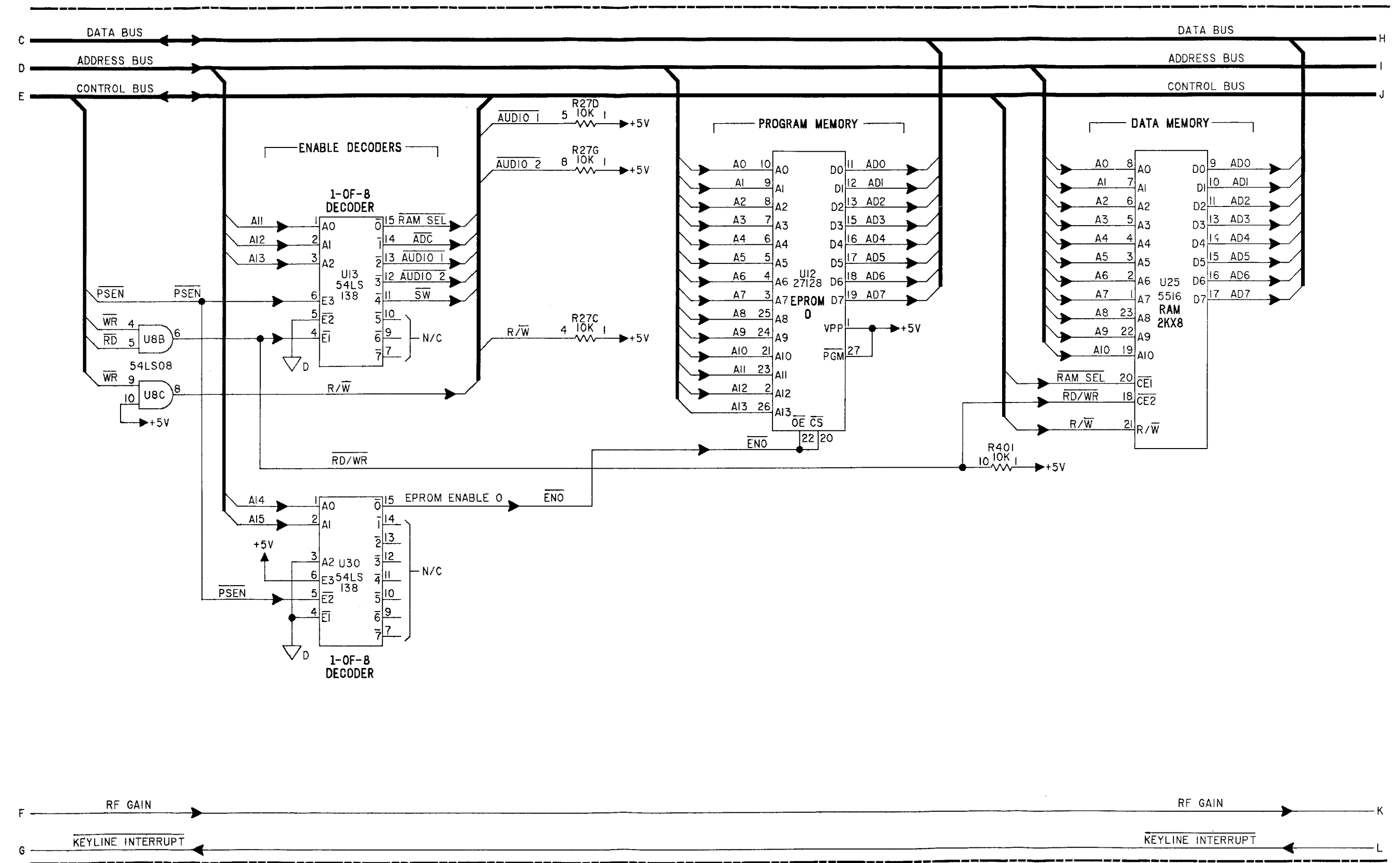

FO-6. Audio/Microprocessor PWB Assy, A2 (Sheet 3 of 19)

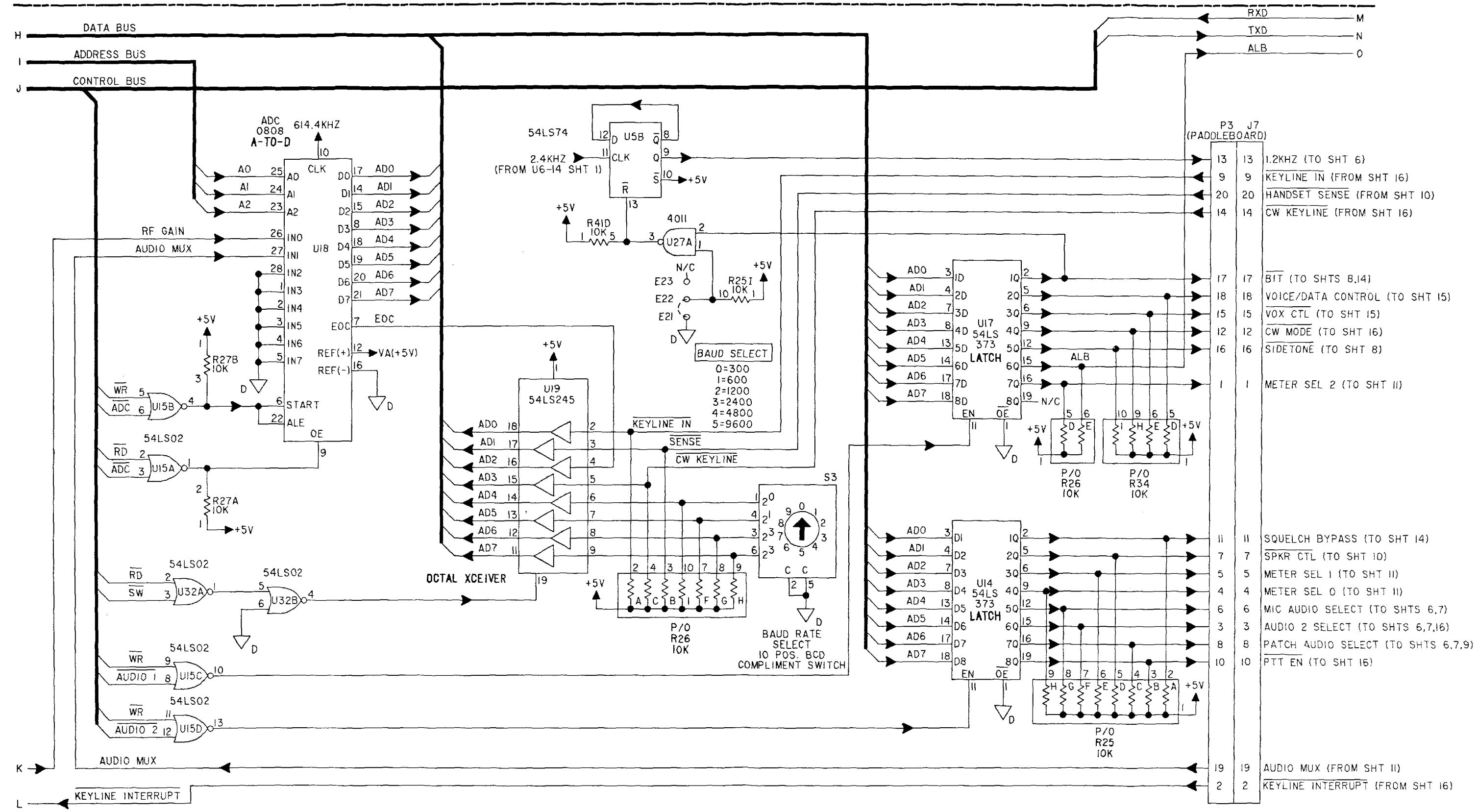

FO-6. Audio/Microprocessor PWB Assy, A2 (Sheet 4 of 19)

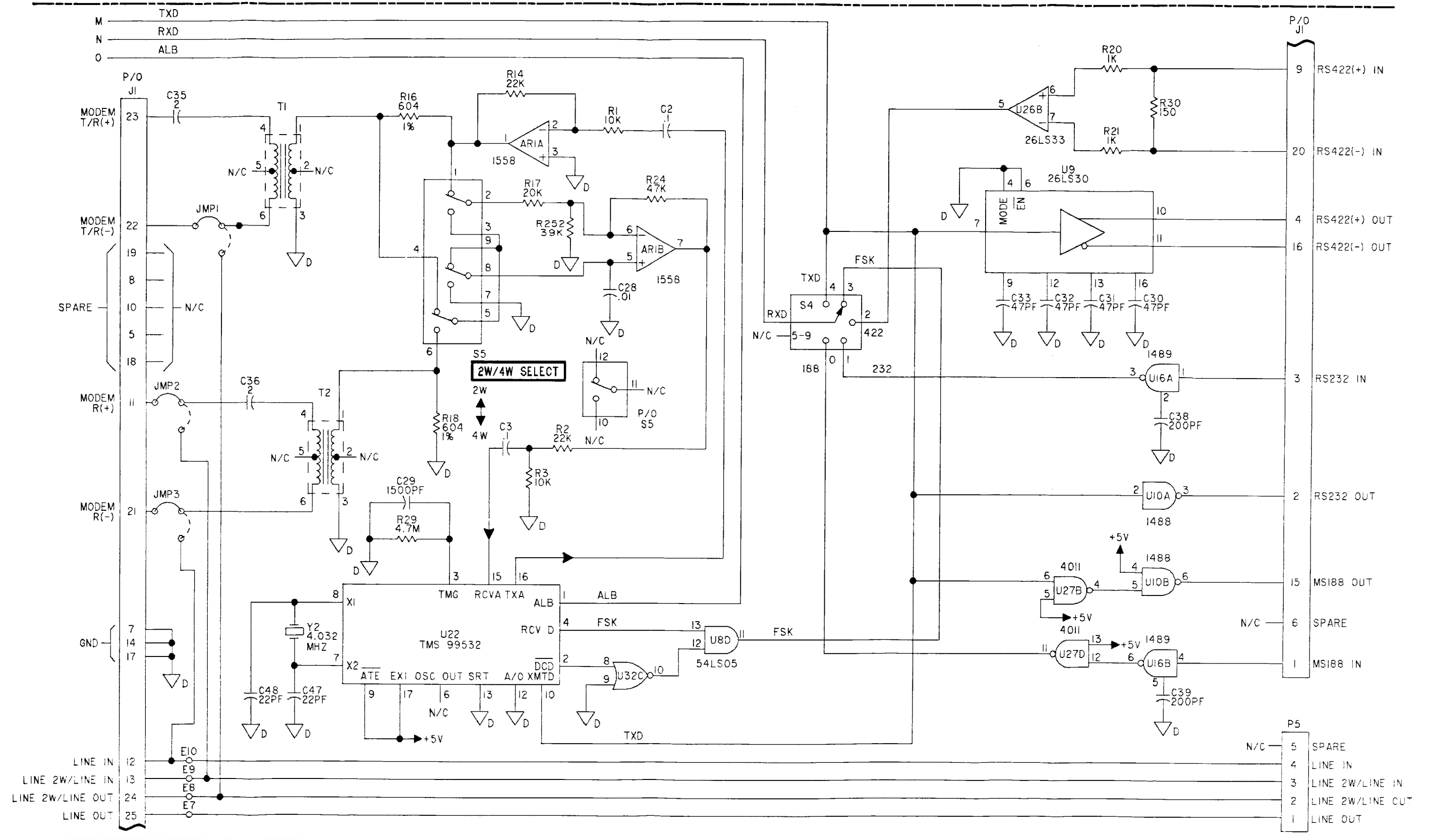

FO-6. Audio/Microprocessor PWB Assy, A2 (Sheet 5 of 19)

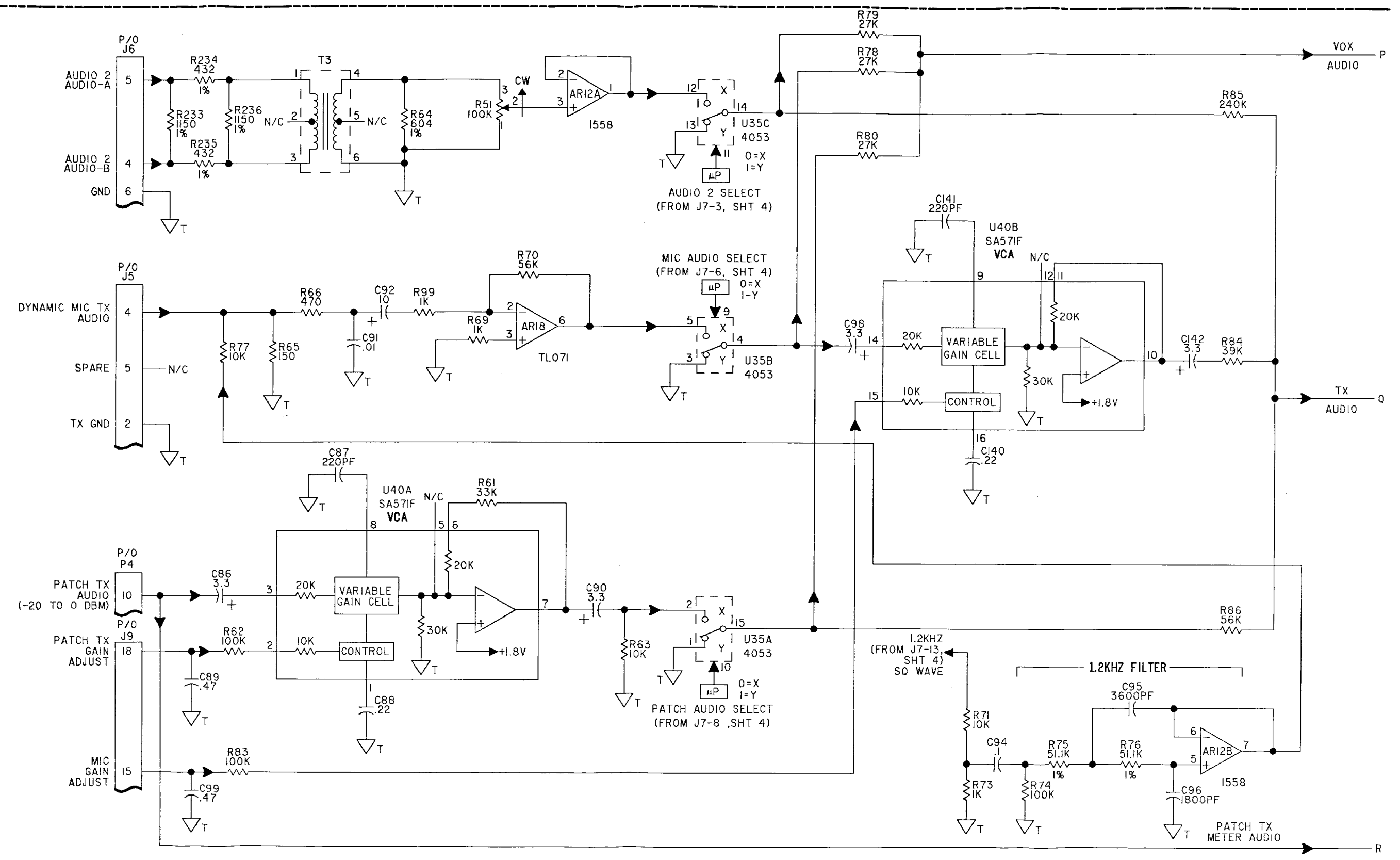

FO-6. Audio/Microprocessor PWB Assy, A2 (Sheet 6 of 19)

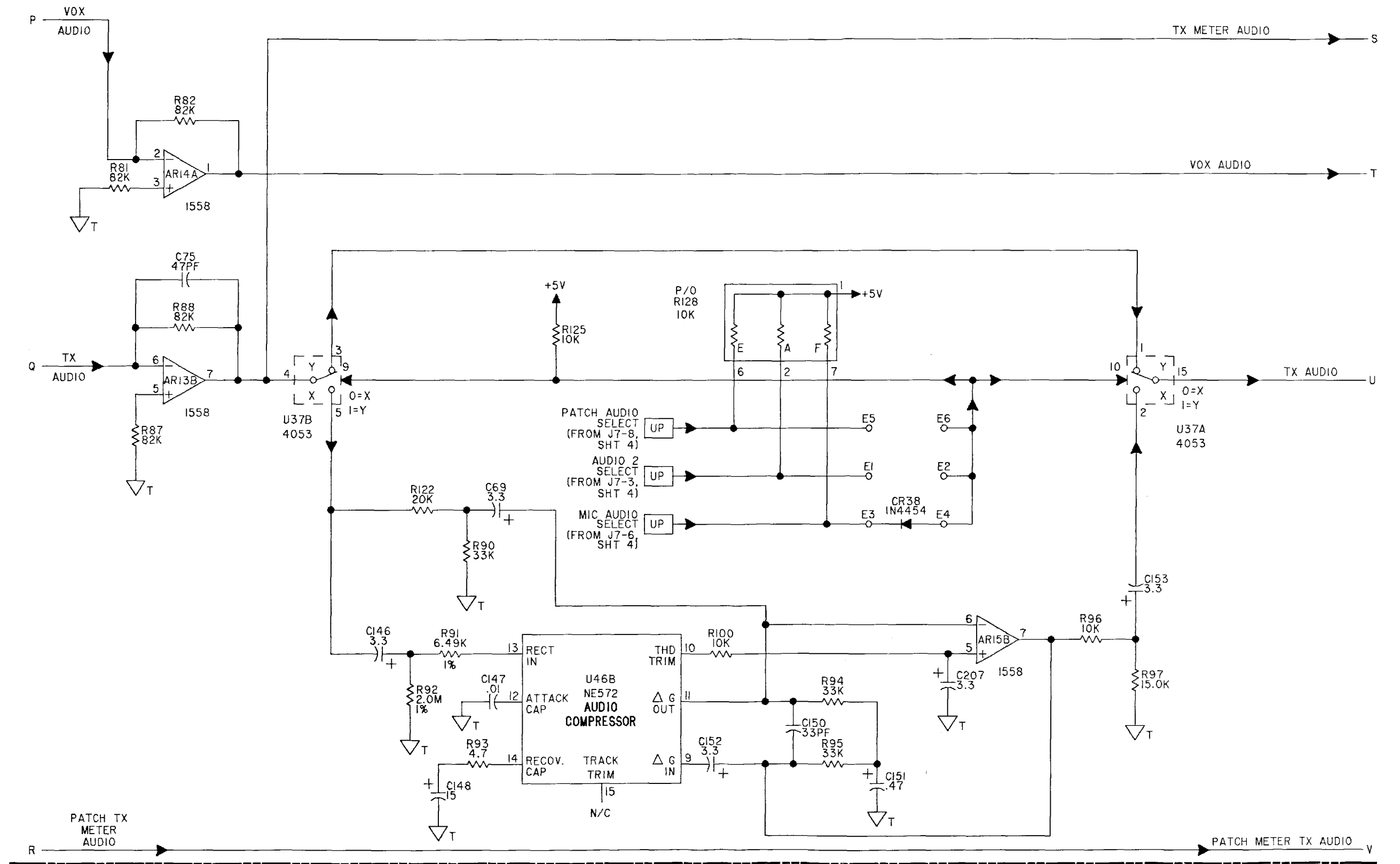

FO-6. Audio/Microprocessor PWB Assy, A2
(Sheet 7 of 19)

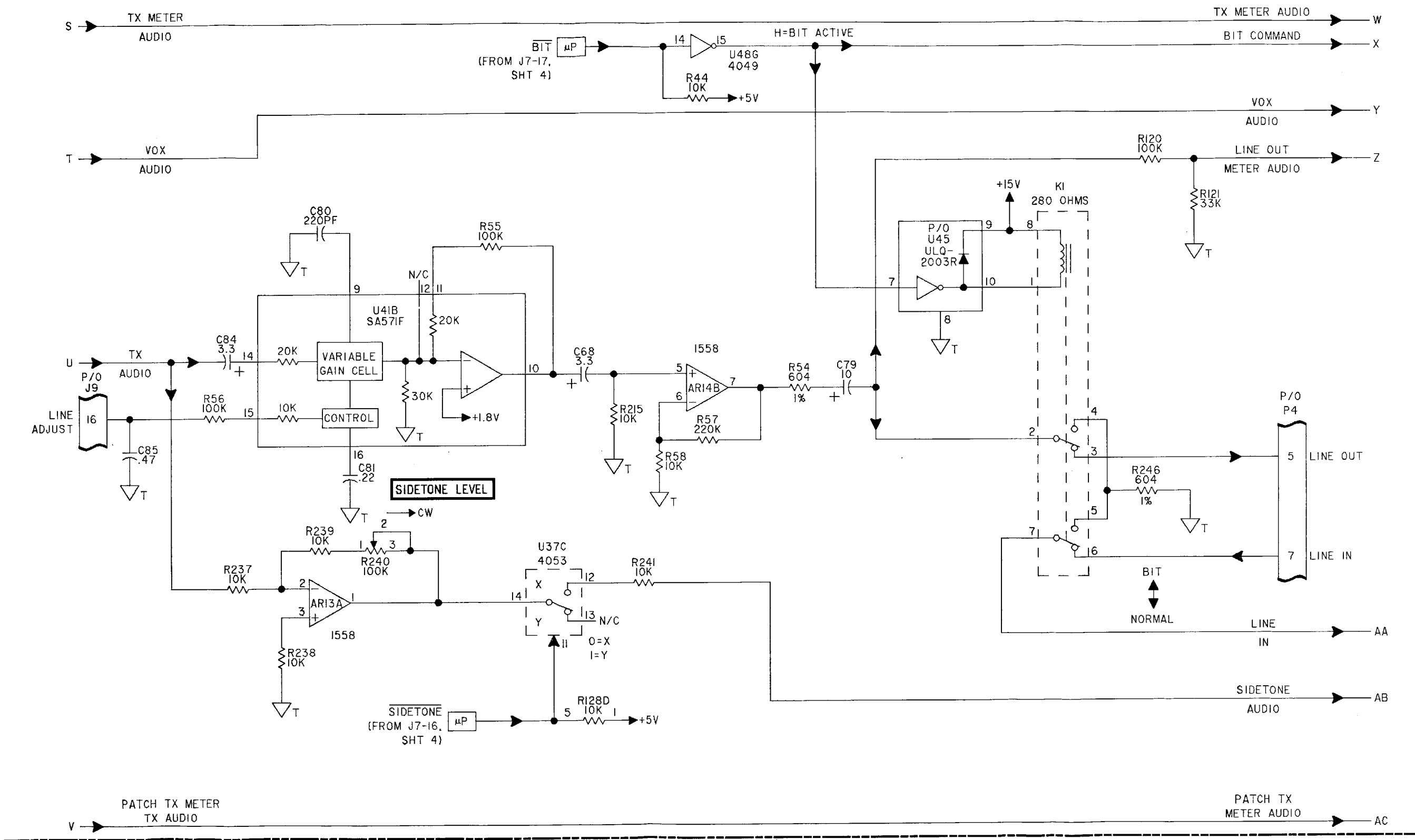

FO-6. Audio/Microprocessor PWB Assy, A2 (Sheet 8 of 19)

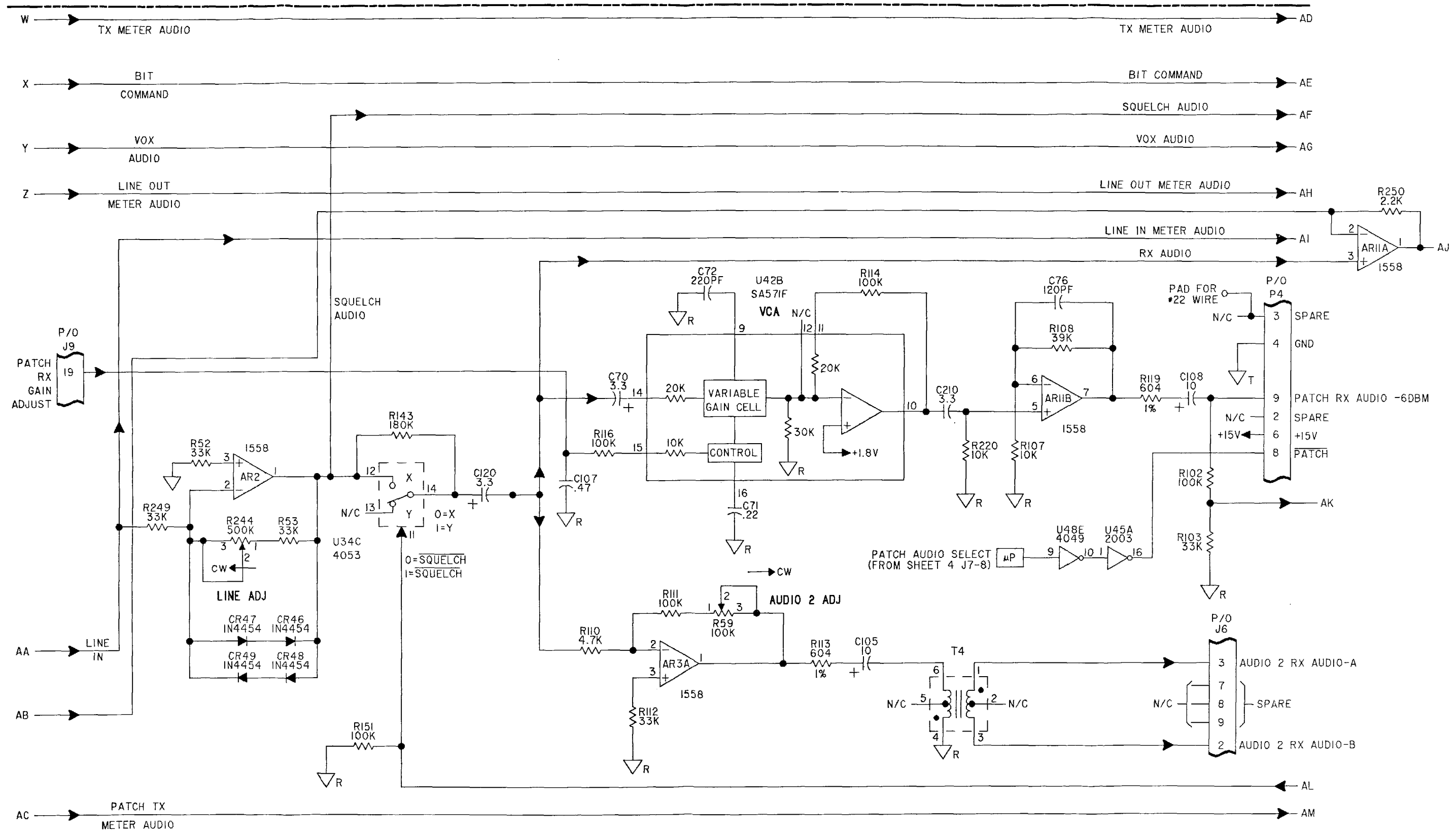

FO-6. Audio/Microprocessor PWB Assy, A2 (Sheet 9 of 19)

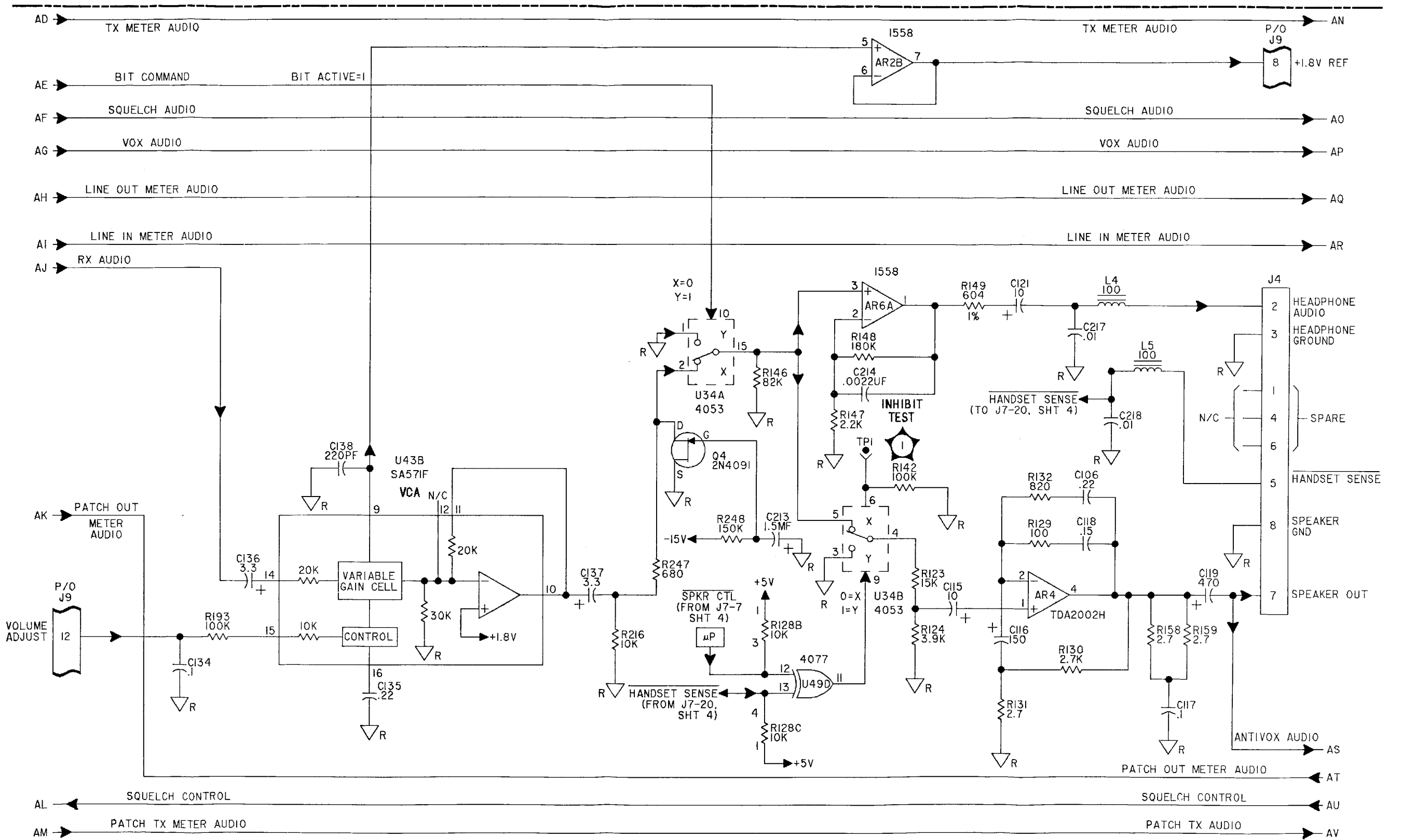

FO-6. Audio/Microprocessor PWB Assy, A2 (Sheet 10 of 19)

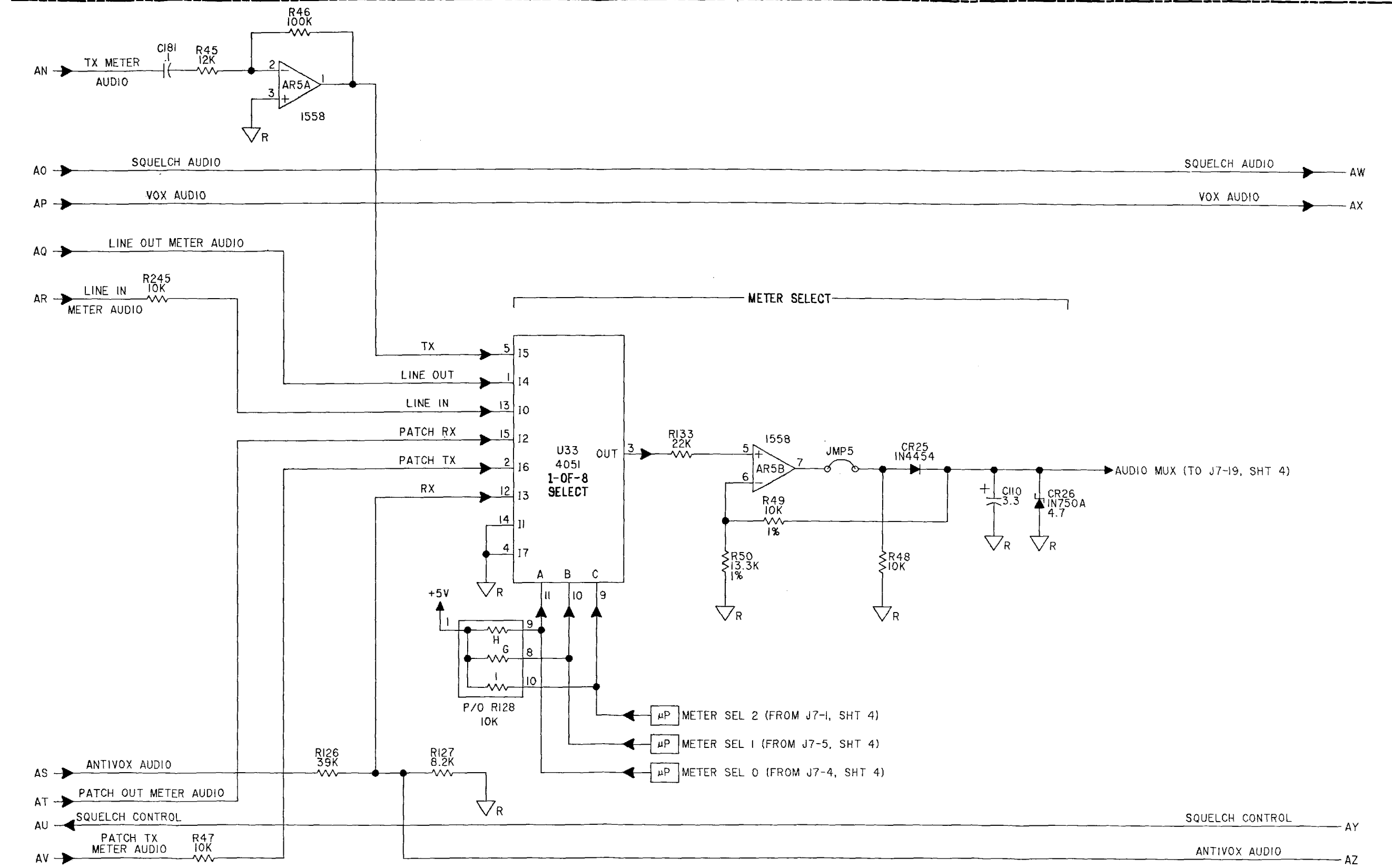

FO-6. Audio/Microprocessor PWB Assy, A2 (Sheet 11 of 19)

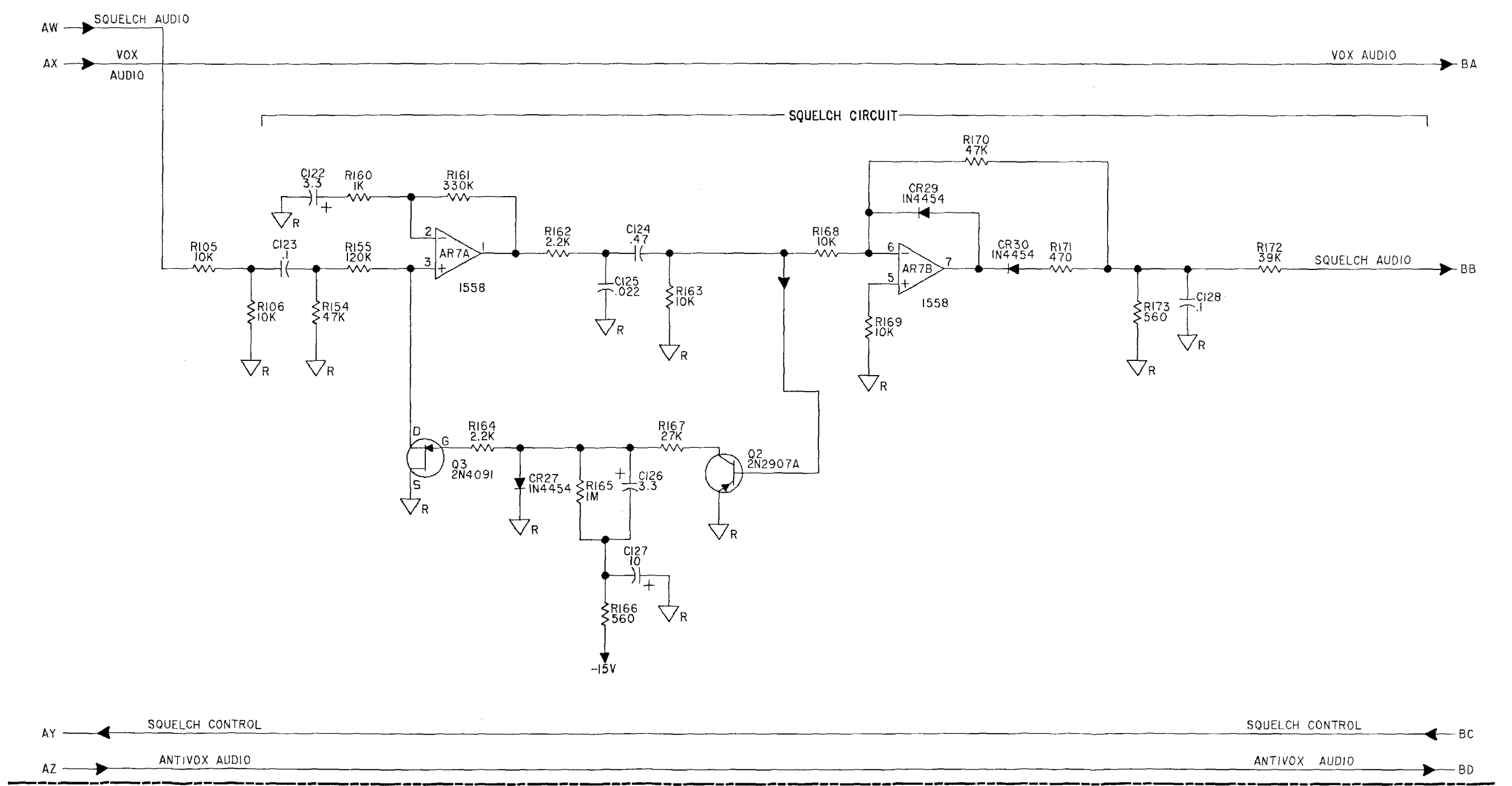

FO-6. Audio/Microprocessor PWB Assy, A2
(Sheet 12 of 19)

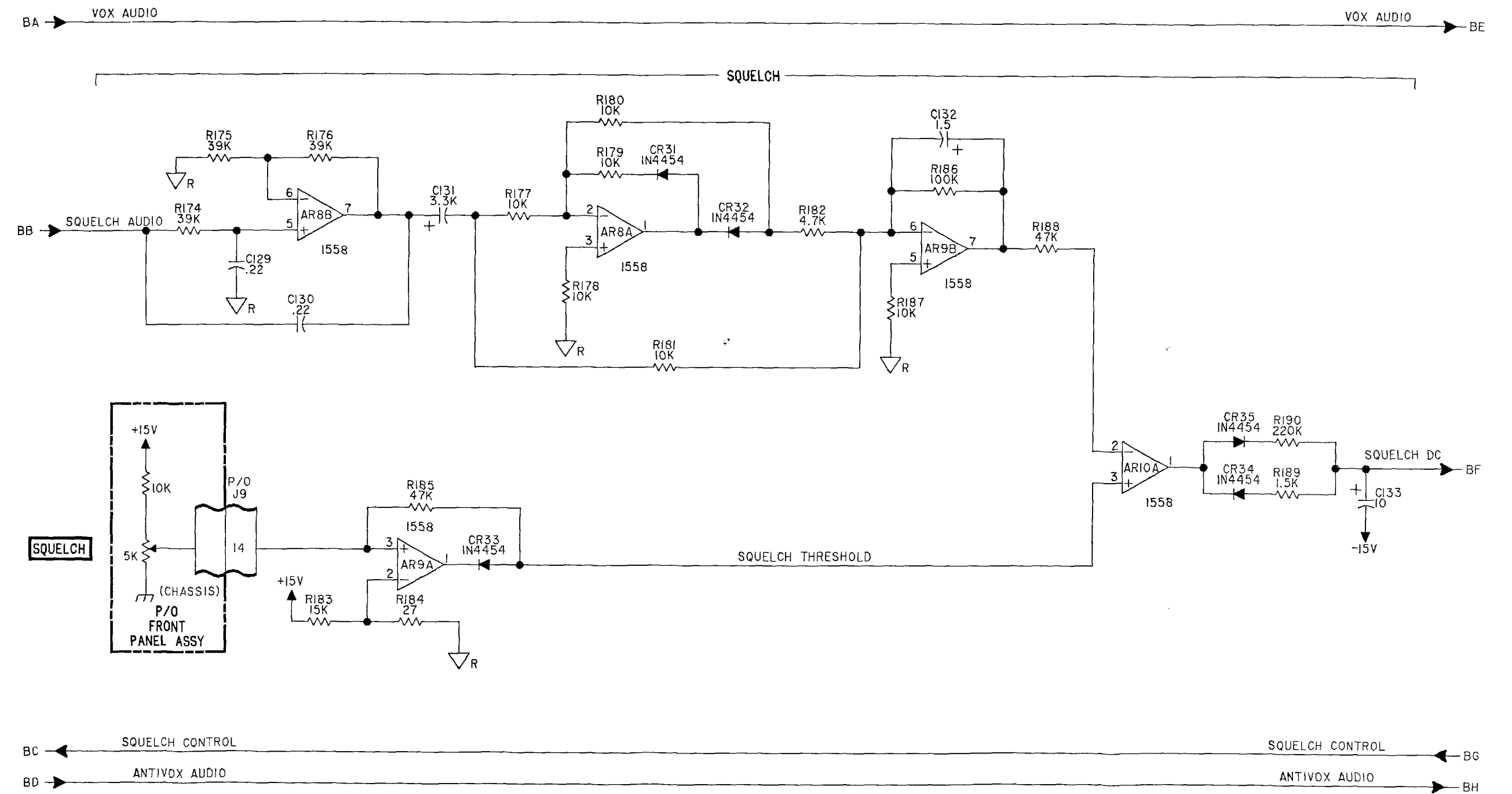

FO-6. Audio/Microprocessor PWB Assy, A2
(Sheet 13 of 19)

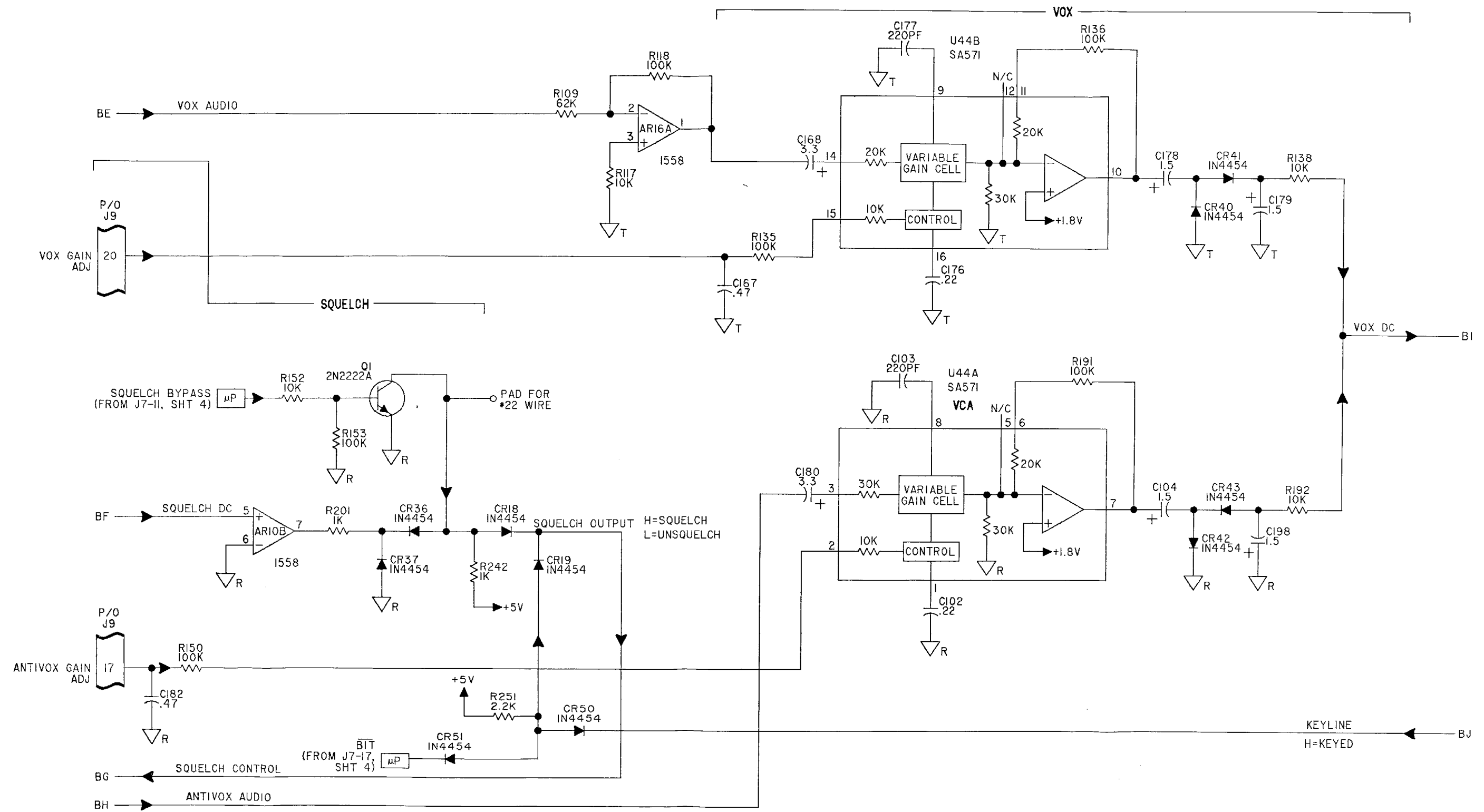

FO-6. Audio/Microprocessor PWB Assy, A2 (Sheet 14 of 19)

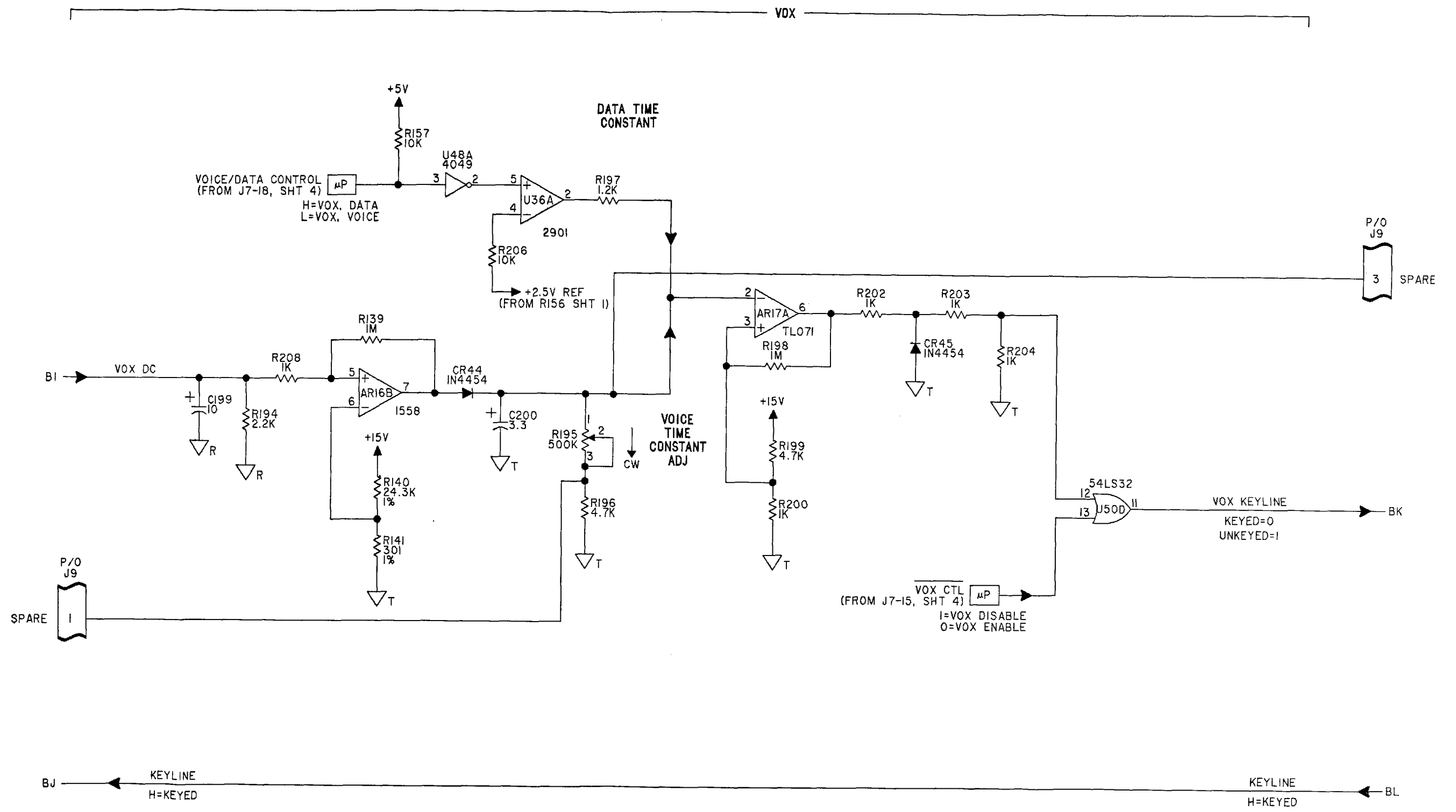

FO-6. Audio/Microprocessor PWB Assy, A2
(Sheet 15 of 19)

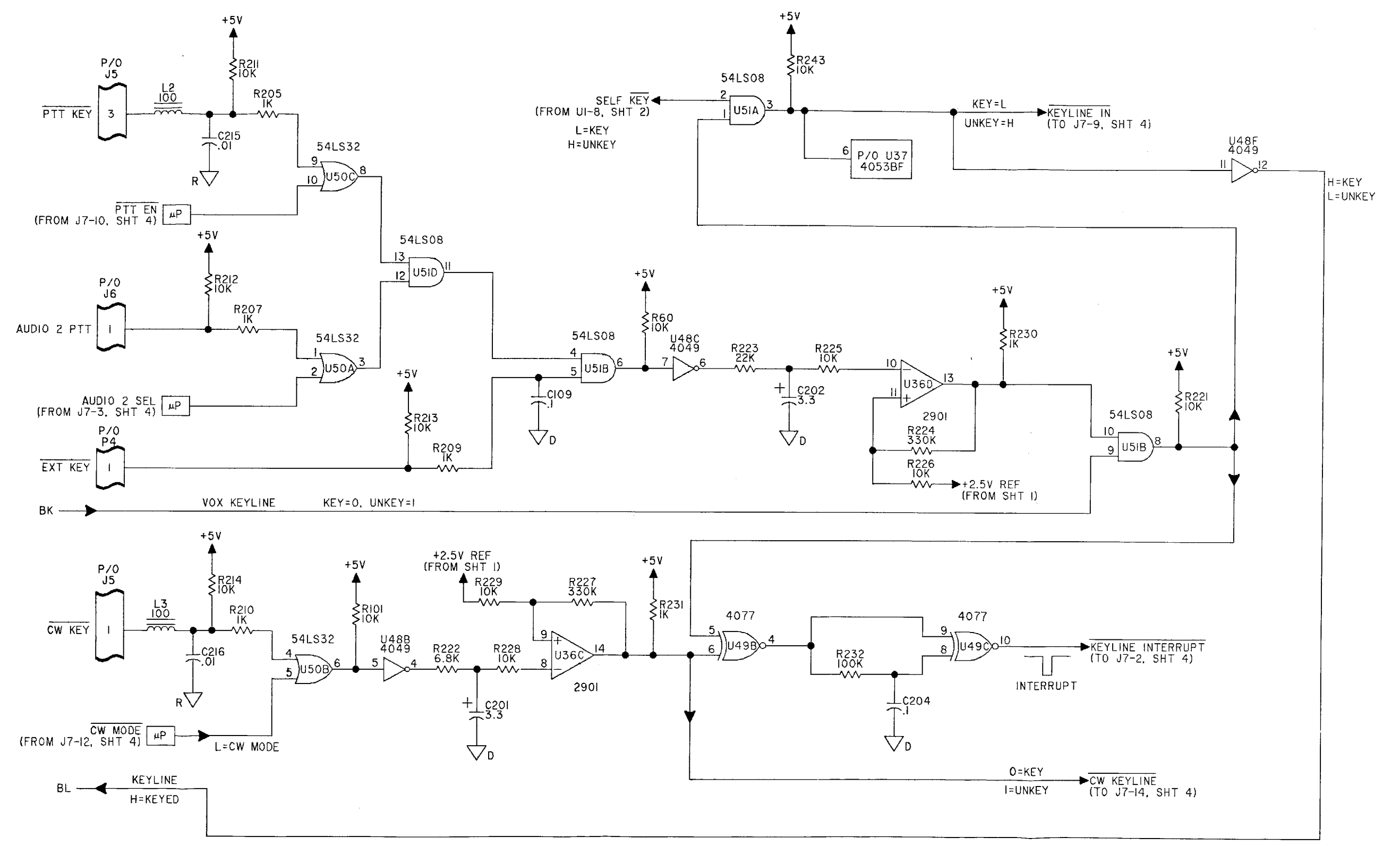

FO-6. Audio/Microprocessor PWB Assy, A2 (Sheet 16 of 19)

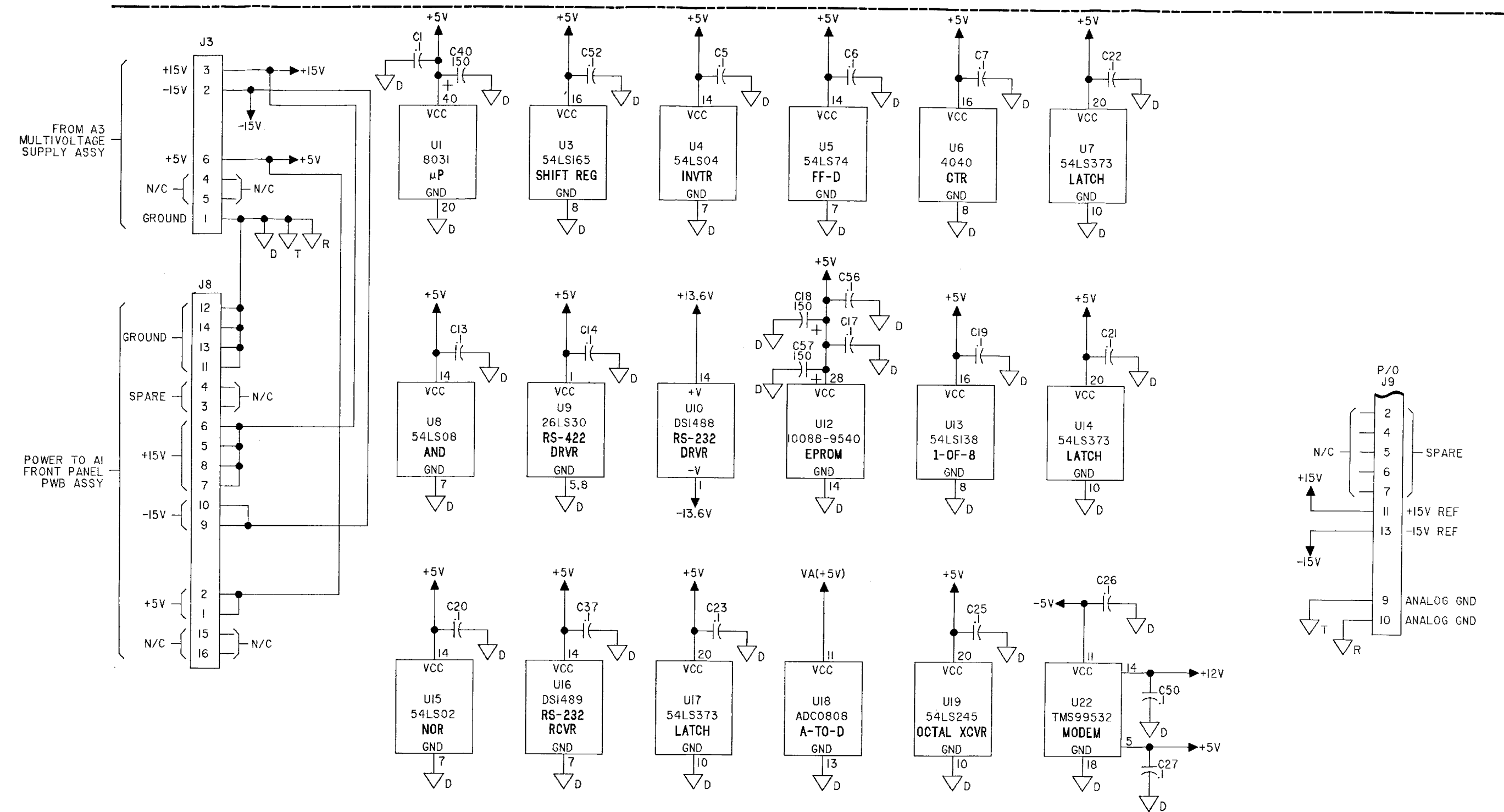

FO-6. Audio/Microprocessor PWB Assy, A2 (Sheet 17 of 19)

DEVICE POWER CONNECTIONS

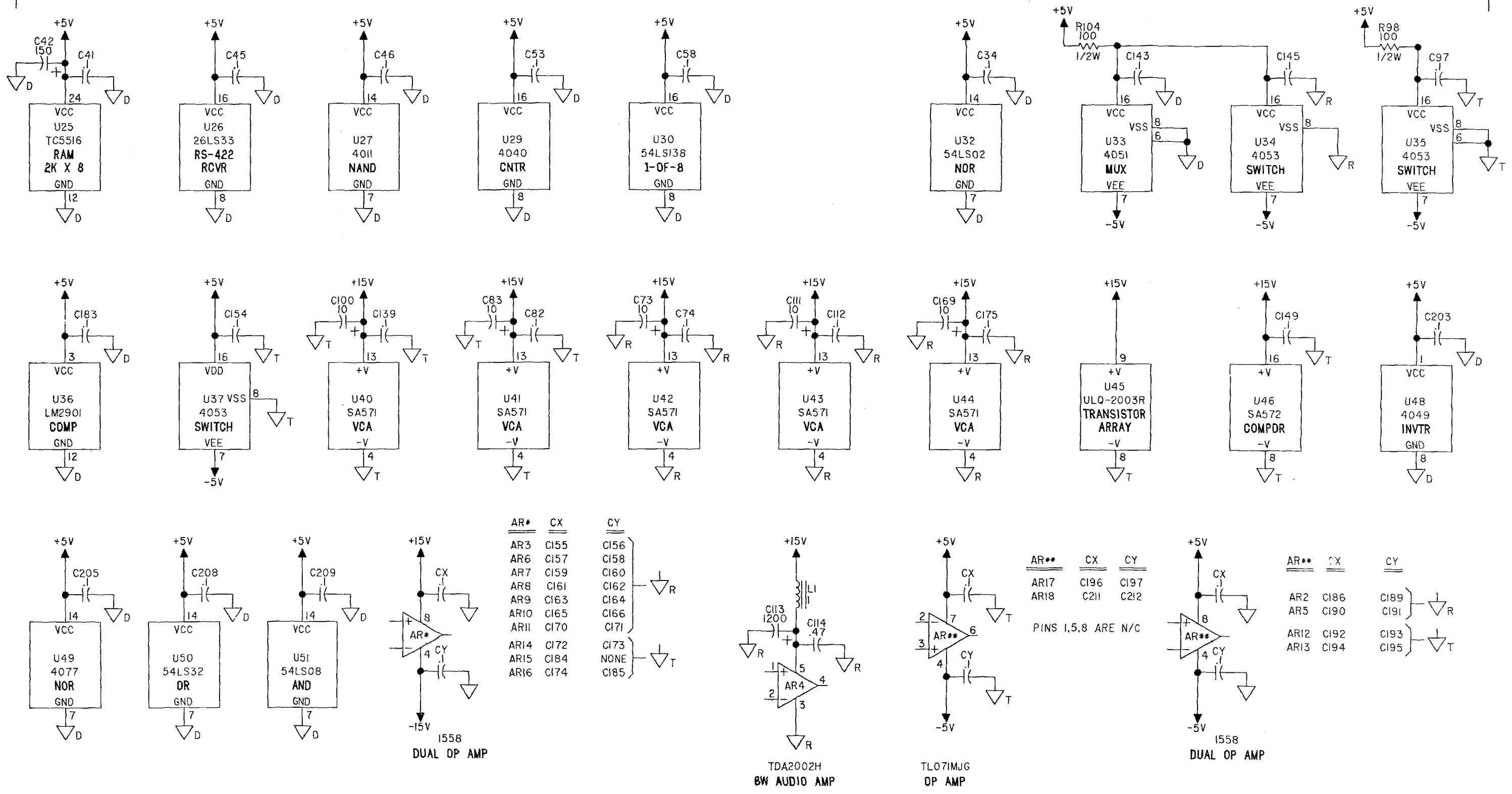

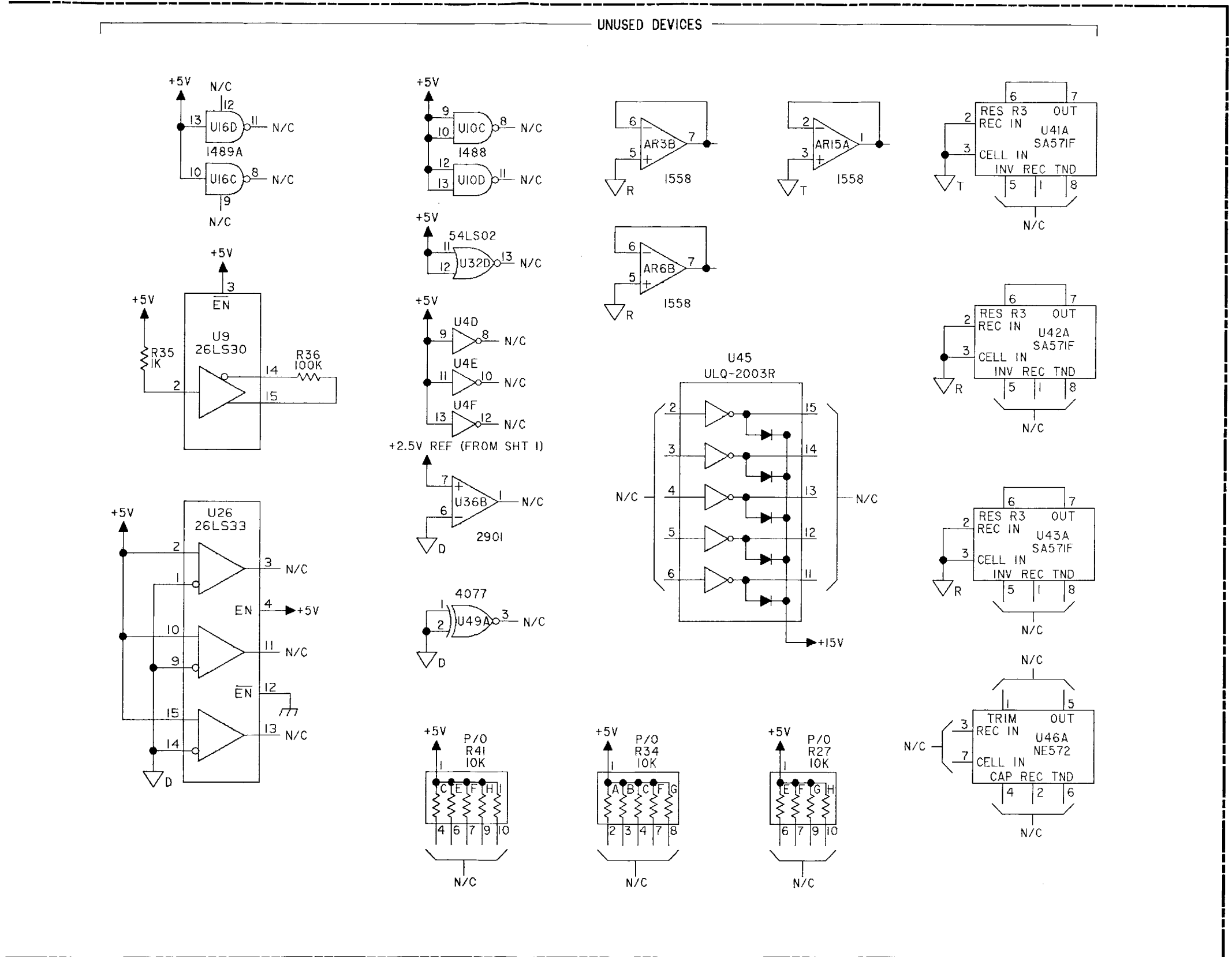

FO-6. Audio/Microprocessor PWB Assy, A2
(Sheet 19 of 19)

NOTE: UNLESS OTHERWISE SPECIFIED:

1. PARTIAL REFERENCE DESIGNATIONS ARE SHOWN FOR DETAIL PARTS. PREFIX THESE WITH UNIT NO. AND/OR ASSEMBLY DESIGNATIONS SHOWN ON DRAWING TO OBTAIN COMPLETE DESIGNATIONS.
2. ALL RESISTOR VALUES ARE IN OHMS, 1/4W, ±5%.
3. ALL CAPACITOR VALUES ARE IN MICROFARADS (μF).
4. ALL INDUCTANCE VALUES ARE IN MICROHENRIES (μH).
5. VENDOR PART NO. CALLOUTS ARE FOR REFERENCE ONLY. COMPONENTS ARE SUPPLIED PER PART NO. IN PARTS LIST.
6. DC RESISTANCES OF INDUCTIVE ELEMENTS (CHOKES, COILS, MOTOR WINDINGS, ETC.) ARE LESS THAN 1 OHM.
7. PANEL DECALS ARE INDICATED BY BOLD TYPE IN A BOLD BOX, E.G., **ON/OFF**.
8. ALL RELAYS ARE SHOWN IN THE DE-ENERGIZED STATE.

HIGHEST REFERENCE DESIGNATION	
REFERENCE DESIGNATIONS NOT USED	

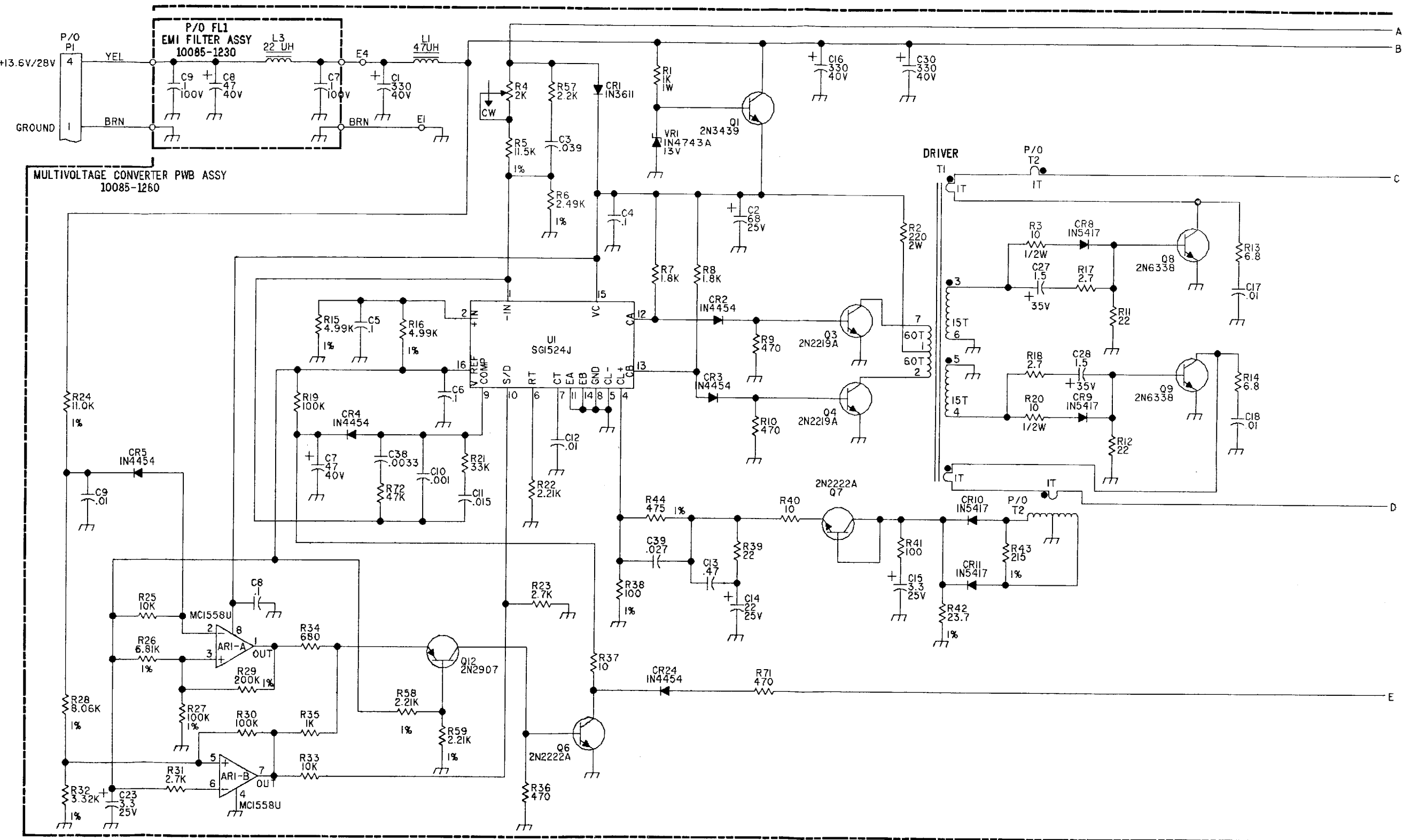

FO-7. Multivoltage Supply PWB Assy, A3A1 (Sheet 1 of 2)

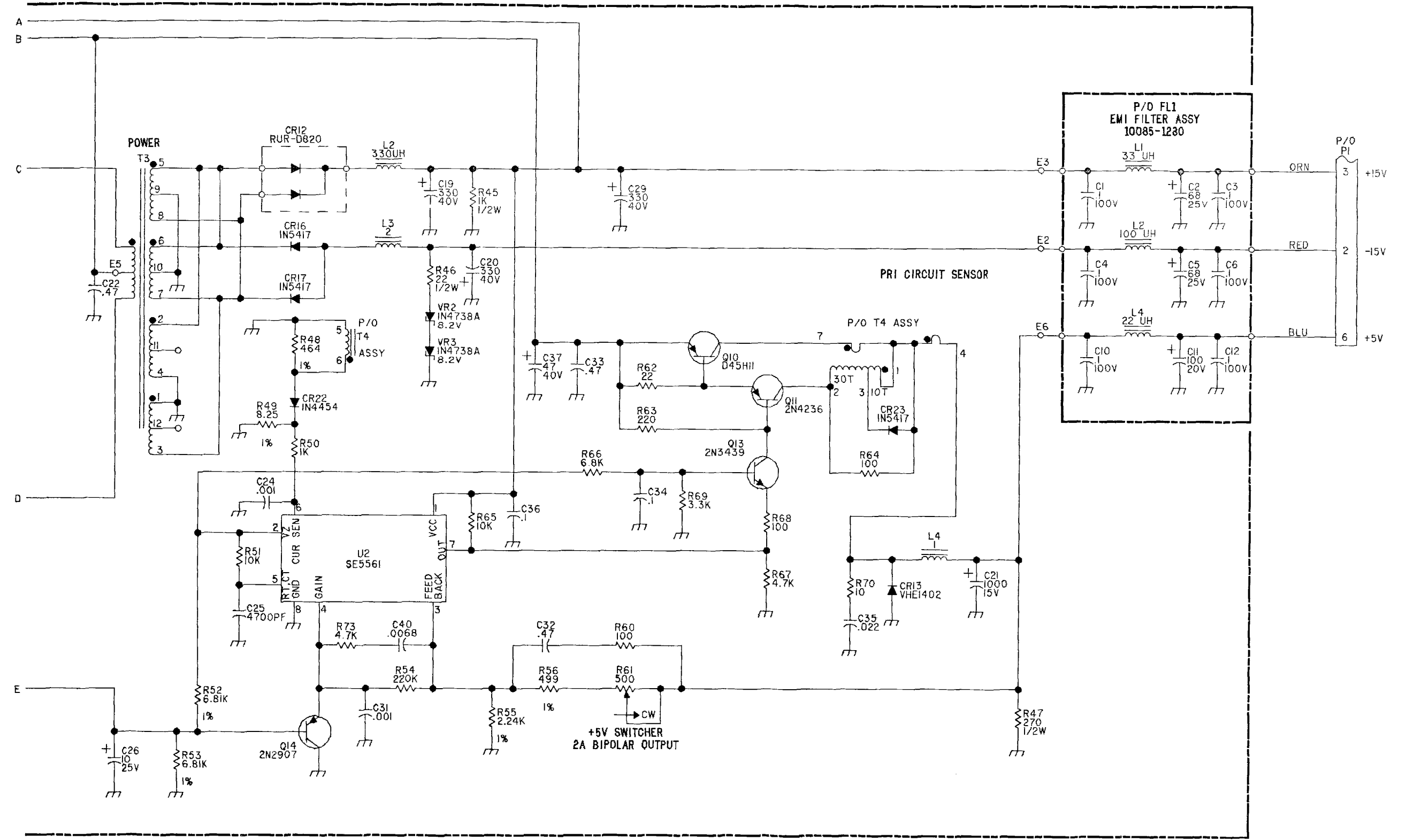

FO-7. Multivoltage Supply PWB Assy, A3A1 (Sheet 2 of 2)

- NOTE: UNLESS OTHERWISE SPECIFIED:
1. PARTIAL REFERENCE DESIGNATIONS ARE SHOWN FOR DETAIL PARTS. PREFIX THESE WITH UNIT NO. AND/OR ASSEMBLY DESIGNATIONS SHOWN ON DRAWING TO OBTAIN COMPLETE DESIGNATIONS.
 2. ALL RESISTOR VALUES ARE IN OHMS, 1/4W, ±5%.
 3. ALL CAPACITOR VALUES ARE IN MICROFARADS (μF).
 4. ALL INDUCTANCE VALUES ARE IN MICROHENRIES (Mμ).
 5. VENDOR PART NO. CALLOUTS ARE FOR REFERENCE ONLY. COMPONENTS ARE SUPPLIED PER PART NO. IN PARTS LIST.
 6. DC RESISTANCES OF INDUCTIVE ELEMENTS (CHOKES, COILS, MOTOR WINDINGS, ETC.) ARE LESS THAN 1 OHM.
 7. PANEL DECALS ARE INDICATED BY BOLD TYPE IN A BOLD BOX, E.G., **ON/OFF**.
 8. ALL RELAYS ARE SHOWN IN THE DE-ENERGIZED STATE.

HIGHEST REFERENCE DESIGNATION				
REFERENCE DESIGNATIONS NOT USED				

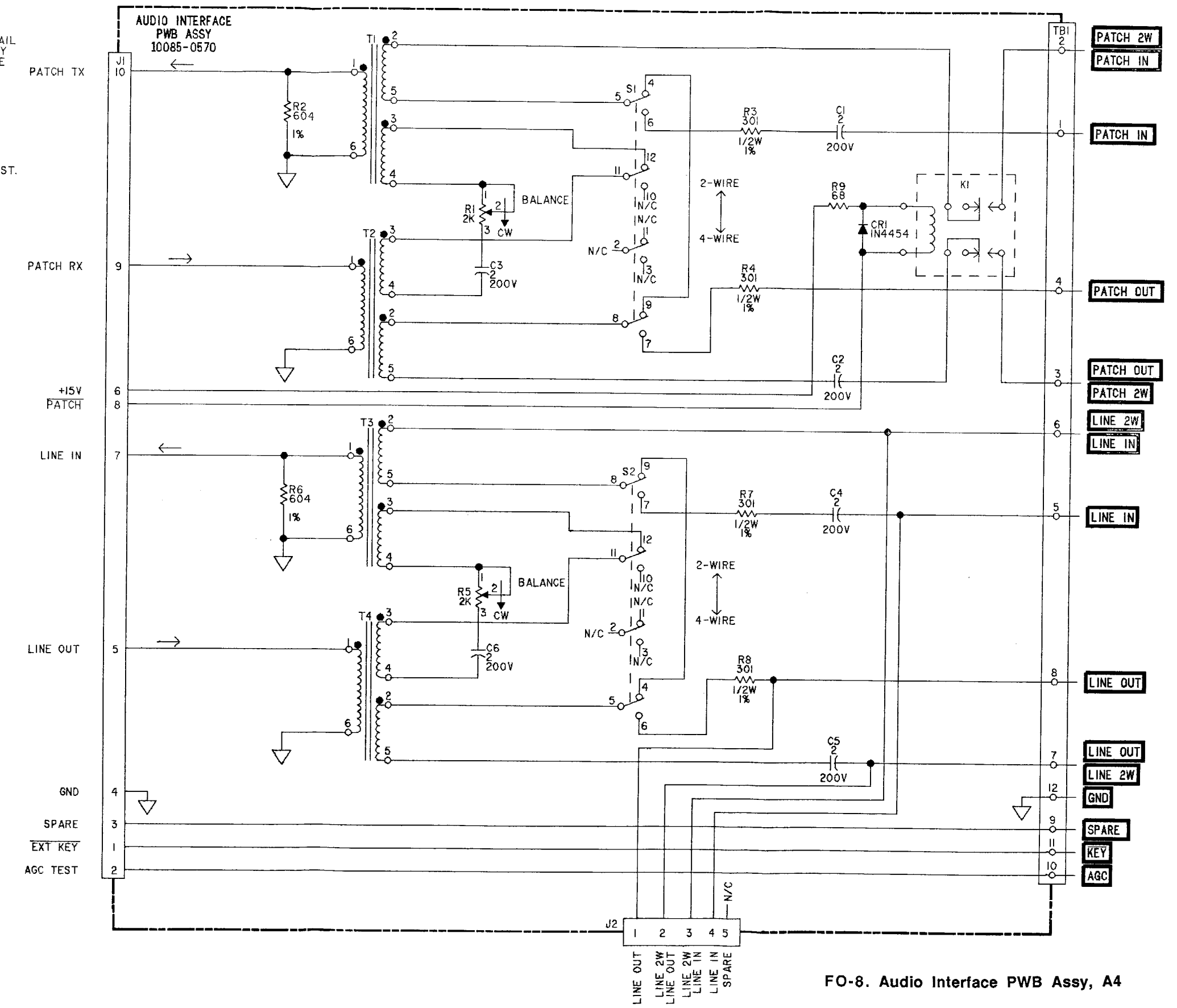

FO-8. Audio Interface PWB Assy, A4

NOTE: UNLESS OTHERWISE SPECIFIED:

1. PARTIAL REFERENCE DESIGNATIONS ARE SHOWN FOR DETAIL PARTS. PREFIX THESE WITH UNIT NO. AND/OR ASSEMBLY DESIGNATIONS SHOWN ON DRAWING TO OBTAIN COMPLETE DESIGNATIONS.
2. ALL RESISTOR VALUES ARE IN OHMS, 1/4W, ±5%.
3. ALL CAPACITOR VALUES ARE IN MICROFARADS (µF).
4. ALL INDUCTANCE VALUES ARE IN MICROHENRIES (µH).
5. VENDOR PART NO. CALLOUTS ARE FOR REFERENCE ONLY. COMPONENTS ARE SUPPLIED PER PART NO. IN PARTS LIST.
6. DC RESISTANCES OF INDUCTIVE ELEMENTS (CHOKES, COILS, MOTOR WINDINGS, ETC.) ARE LESS THAN 1 OHM.
7. PANEL DECALS ARE INDICATED BY BOLD TYPE IN A BOLD BOX, E.G., **ON/OFF**
8. ALL RELAYS ARE SHOWN IN THE DE-ENERGIZED STATE.

HIGHEST REFERENCE DESIGNATION	
REFERENCE DESIGNATIONS NOT USED	
UNUSED GATES	

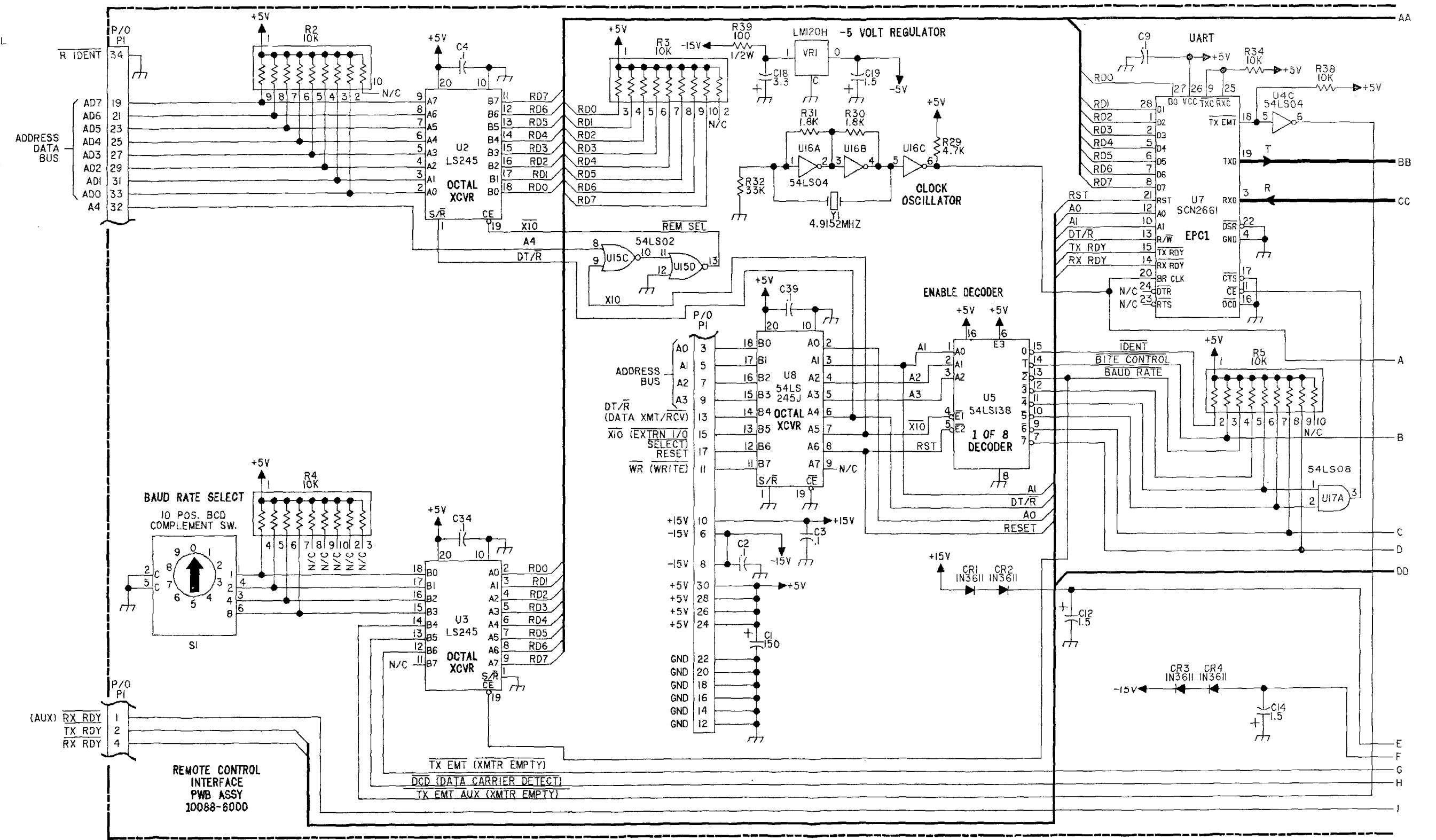
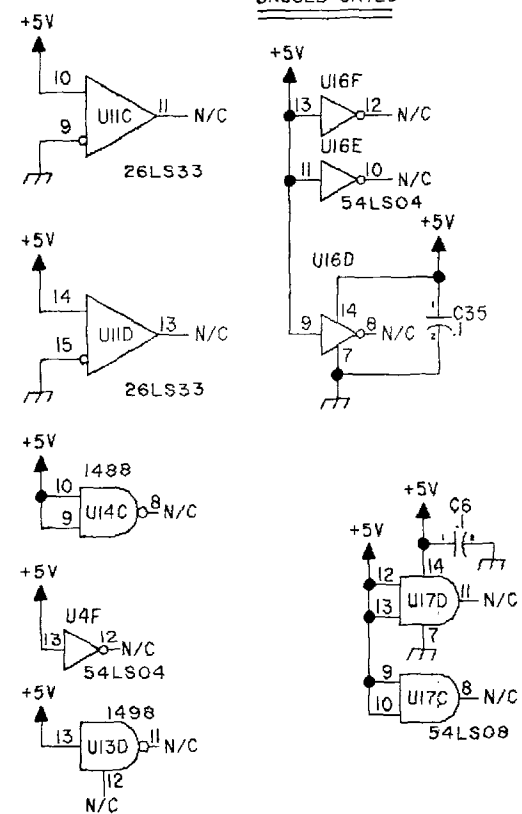

FO-9. Remote Control Interface PWB Assy, A1A19 (in Transceiver) (Sheet 1 of 3)

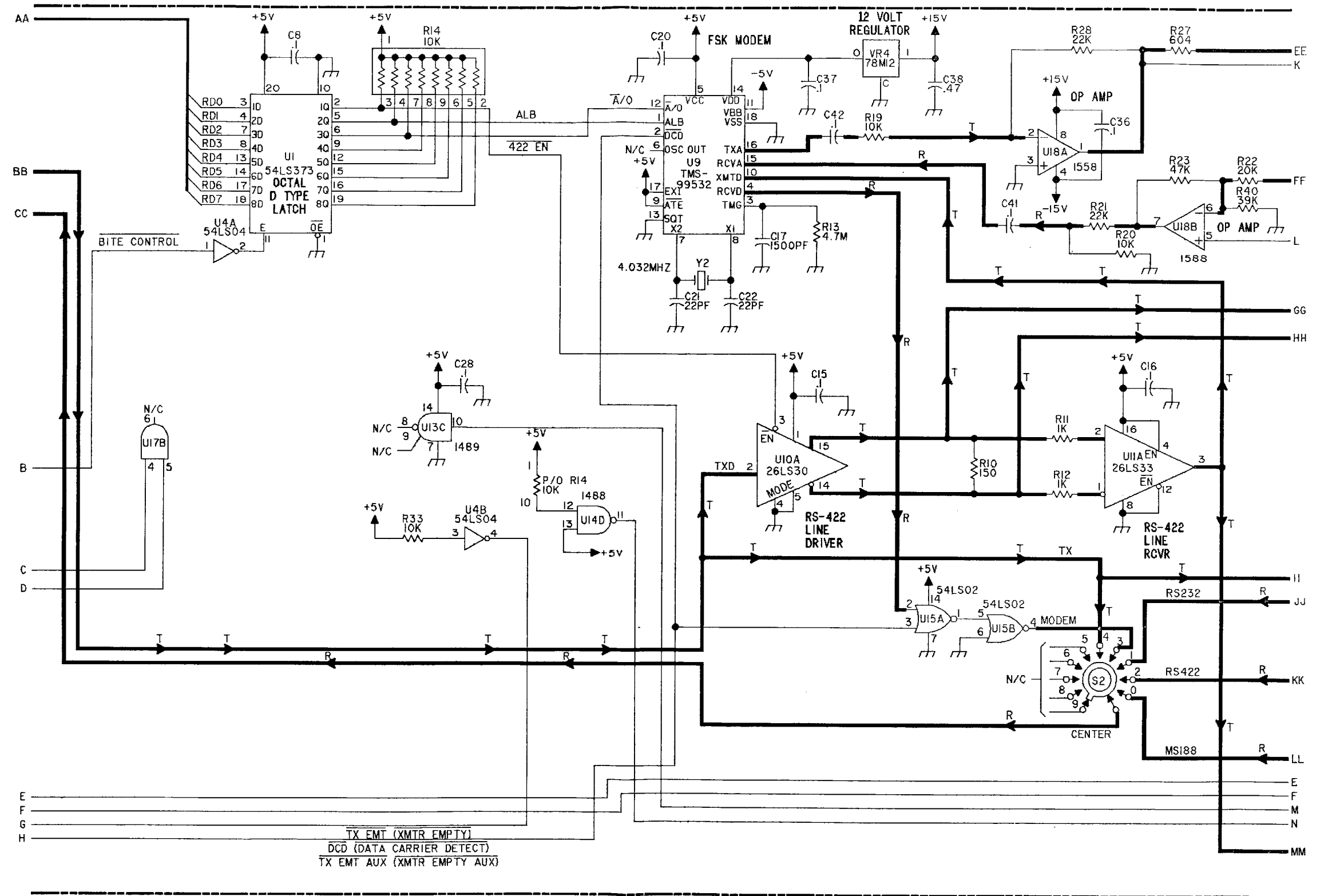

FO-9. Remote Control Interface PWB Assy, A1A19 (in Transceiver) (Sheet 2 of 3)

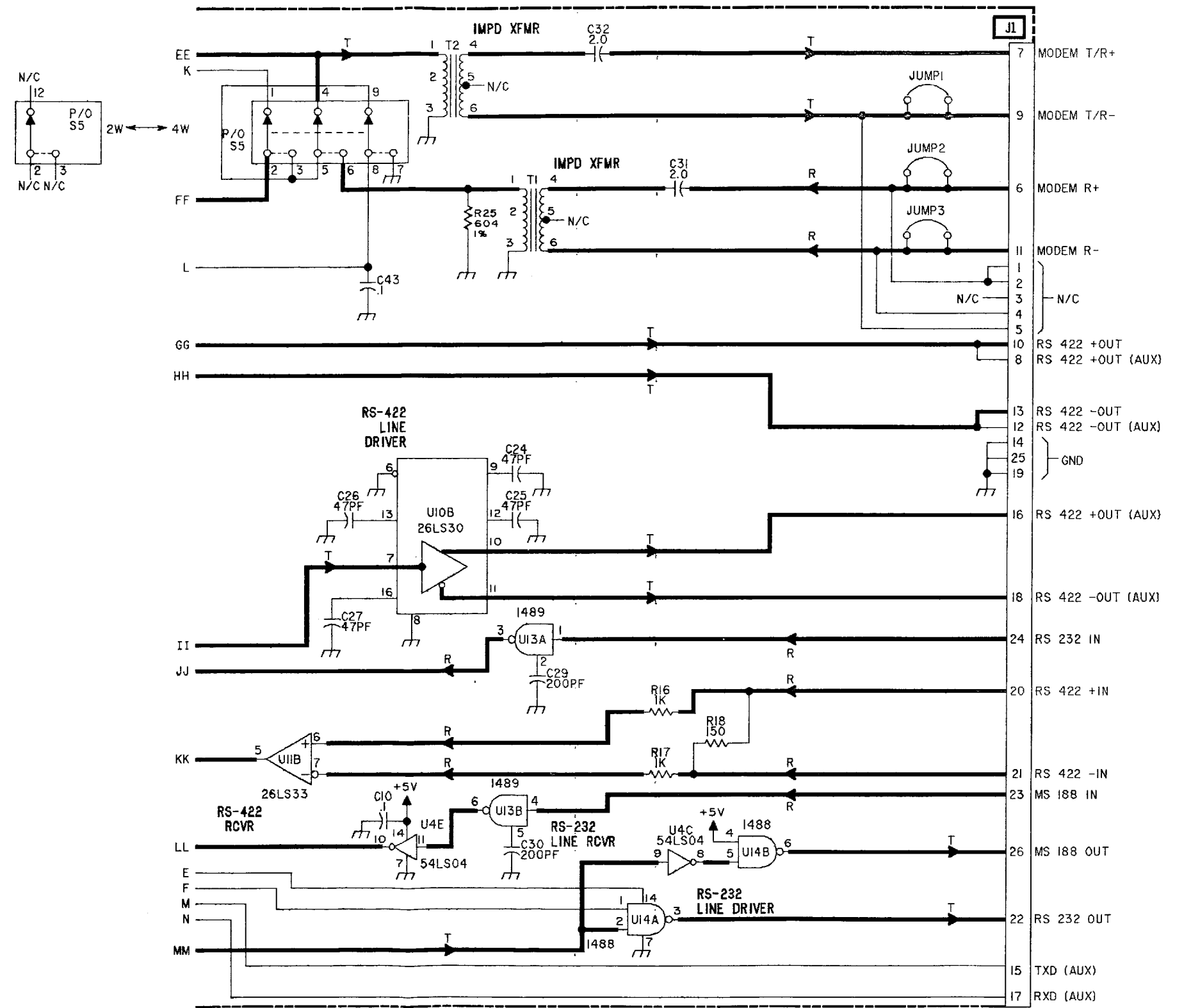

FO-9. Remote Control Interface PWB Assy, A1A19 (in Transceiver) (Sheet 3 of 3)

